

MDRIVE 17™ MOTOR+DRIVER 17

SPEED CONTROL

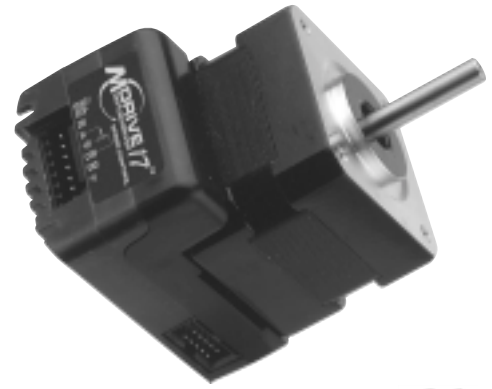

FEATURES

- Integrated Variable Speed Control, Driver and NEMA 17 High Torque Motor
- +12 to +48 VDC Input Voltage
- Digital Oscillator for Accurate Speed Control
- Low Cost
- Extremely Compact
- Available Configurations:
 - Single Shaft*
 - Long Life Linear Actuator
 - Factory-Mounted Optical Encoder*
 - Double Shaft End with Knob For Manual Positioning*
- Available in Three Motor Lengths*
- Electronically Configurable (Eliminates Potentiometers):
 - Motor Run/Hold Current
 - Acceleration/Deceleration
 - Initial and Max Velocity
 - Microstep Resolution to 256 Microsteps/Full Step
- 2 Modes of Operation: Bidirectional or Unidirectional
- 0 to +5 VDC, 4 - 20mA or 15 - 25kHz PWM Speed Control Input with Programmable Center Point
- Single Supply
- Interface Uses Pluggable Terminal Strip or Optional 12" (30.5 cm) Flying Leads
- Graphical User Interface (GUI) for Quick and Easy Parameter Setup

*Rotary Motor Only

DESCRIPTION

The MDrive17 Speed Control offers the system designer low cost, intelligent velocity control integrated with a NEMA 17 high torque

stepping motor and a +12 to +48 volt microstepping drive.

The MDrive17 Speed Control features a digital oscillator for accurate velocity control with an output frequency of up to 100 kilohertz. Output frequency will vary with the signal applied to the speed control input. Speed can be adjusted by 15 - 25kHz PWM, 4 - 20mA or 0 to 5 volts.

There are two basic modes of operation: bidirectional and unidirectional. By moving the center point, both speed and direction are controlled by the analog speed control input. By setting the center point to zero or the lower end of the potentiometer, only velocity is controlled by the speed control input; direction is controlled by a separate digital input.

The MDrive17 Speed Control has 12 setup parameters which are configured using the included Configuration Utility. These enable the user to configure all of the operational parameters of the MDrive17 which are stored in non-volatile memory.

The versatile, compact MDrive17 Speed Control is available in multiple configurations to fit various system needs. These options include: a single shaft stand-alone device, a dual shaft rotary motor with optical encoder or control knob, or a long life ACME screw linear actuator. The rotary MDrive17 Speed Control is also available in three different motor lengths: 13, 15 & 19. Interface

connections are accomplished using either a 7 position terminal strip or optional 12" (30.5 cm) flying leads.

CONFIGURATION UTILITY

The IMS Analog Speed Control software is a required, easy to install and use graphical user interface (GUI) for configuring the MDrive17 Speed Control from the parallel port on your computer. Access the GUI via the IMS SPI Interface included on the CD shipped with the product, or download at www.imshome.com. An optional parameter setup cable is available for ease of connecting and configuring this MDrive product.

Configuration Utility features include:

- Easy installation.
- Automatic detection of MDrive version and communication configuration.
- Will not set out-of-range values.
- Tool-tips display valid range setting for each option.
- Ease of use via single screen interface (*shown below*).



The IMS Speed Control Interface GUI simplifies MDrive configuring with a single screen interface.

MDRIVE 17 SPEED CONTROL SPECIFICATIONS

ELECTRICAL SPECIFICATIONS

Speed Control Input	0 to +5 VDC, 15 to 25kHz PWM or 4 to 20mA
A/D Resolution	10 bit
Speed Control Potentiometer Resistance	10 k Ω
Input Voltage (+V) Range	+12 to +48 VDC
Stop/Start, Direction (Low Level Input)	0 to +1.5 VDC
Stop/Start, Direction (High Level Input)	+3.0 to +5.0 VDC
Input Pull-up Resistance (to +5 VDC) Stop/Start, Direction	4.99 k Ω

PARAMETERS

SETUP PARAMETERS				
NAME	FUNCTION	RANGE	UNITS	DEFAULT
ACCL	Accel/Decel	2000 to 100000	steps/sec ²	2000
C	Joystick Center	0 to 1022	counts	0
DB	Deadband	0 to 255	counts	1
DCLT	Decel Type	Decel at ACCL Rate/No Decel	--	Decel
IMODE	Input Mode	Voltage-PWM/4-20mA	--	V/PWM
FS	Full Scale	1 to 1023	counts	1023
MHC	Hold Current	0 to 100	percent	5
MRC	Run Current	1 to 100	percent	25
MSEL	Microstep Resolution	2, 4, 5, 8, 10, 16, 25, 32, 50, 64, 125, 128, 250, 256	μ steps per step	256
RANGE	VI/VM Range	1 to 8	--	3
VI	Initial Velocity	1 to 100000	steps/sec	400
VM	Maximum Velocity	1 to 100000	steps/sec	20000

All parameters are set using the included Configuration Utility GUI and may be changed on-the-fly. The optional parameter setup cable is recommended with the first order.

PIN ASSIGNMENTS

CONNECTOR P1		
Pin #	Flying Lead	Function
1	Violet	STOP/START INPUT
2	Blue	DIRECTION INPUT
3	Green	0-5V/PWM/4-20mA SPEED CONTROL INPUT (10K POT)*
4	Yellow	+5 VDC OUTPUT (10K POT)*
5	Gray	LOGIC GROUND (10K POT)*
6	Black	POWER GROUND
7	Red	+V (+12 TO +48 VDC)
10 PIN HEADER - P2		
4		CHIP SELECT
5		GROUND
6		+5 VDC OUTPUT
7		MASTER OUT - SLAVE IN
8		CLOCK
10		MASTER IN - SLAVE OUT

* Example Part: 10k ohm, 1/2 W potentiometer such as the Bourns 53AAA-B28-B15 is available from
 - Digi-Key (No.53AAA-B28-B15-ND)
 - Newark Electronics (No.90F6563)

ENCODER PIN ASSIGNMENTS

ENCODER - Single End		ENCODER - Differential			
1	GROUND	1	GROUND	6	CHANNEL A+
2	INDEX	2	+5 VDC INPUT	7	CHANNEL B-
3	CHANNEL A	3	DIRECTION (OUT)	8	CHANNEL B+
4	+5 VDC INPUT	4	STANDBY -	9	INDEX -
5	CHANNEL B	5	CHANNEL A-	10	INDEX +

Recommended Encoder Mating Connectors Listed Below:

Single End Encoder (ES)

Dupont/Berg 78211-005⁽¹⁾, 65039-032 (use either housing with Ultra-High Spring Force Mini PV terminals [48257-000], 22-36 AWG)

Molex/Waldom 50-57-9005 (2695 series) (use 16-02-1125 [2759 series] high pressure terminals, 22-30 AWG)

AMP 103975-4⁽³⁾

Differential Encoder (ED)

3M 89110-0101^(1,2), 89110-0001⁽²⁾

AMP 101798-3⁽³⁾, 87456-6, 101787-1⁽¹⁾, 11918-1, 7462281^(1,2), 746290-1⁽²⁾

Amphenol 842-812-1022-118⁽²⁾, 842-812-1033-118^(1,2)

Dupont/Berg 65043-032, 71602-010^(1,2)

Robinson Nugent IDS-C10NPK-TR⁽²⁾, IDS-C10PK-TR^(1,2)

Thomas & Betts 622-1000⁽²⁾, 622-1030^(1,2)

Molex/Waldom 22-55-2101

⁽¹⁾ Polarized; ⁽²⁾ IDC Ribbon Cable; ⁽³⁾ IDC (Ultra-High or High Spring Force terminals are recommended)

MOTOR SPECIFICATIONS

MD1713

Holding Torque oz-in (N-cm) 32 (22.6)
 Detent Torque oz-in (N-cm) 1.66 (1.17)
 Rotor Inertia oz-in-sec² (kg-cm²) 0.00053 (0.038)
 Weight (Motor+Driver) oz (gm) 8.26 (234.2)

MD1715

Holding Torque oz-in (N-cm) 60.0 (42.4)
 Detent Torque oz-in (N-cm) 2.08 (1.47)
 Rotor Inertia oz-in-sec² (kg-cm²) 0.00080 (0.057)
 Weight (Motor+Driver) oz (gm) 10.42 (295.4)

MD1719

Holding Torque oz-in (N-cm) 74.9 (52.9)
 Detent Torque oz-in (N-cm) 3.47 (2.45)
 Rotor Inertia oz-in-sec² (kg-cm²) 0.00116 (0.082)
 Weight (Motor+Driver) oz (gm) 11.80 (334.5)

Linear

Weight (without screw) oz (gm) 9.2 (260.8)
 Maximum Thrust lbs (kg) 50 (22.7)
 Maximum Screw Deflection ± 1°
 Backlash inches (mm) 0.005 (0.127)

TORQUE-SPEED CURVES

Rotary Motor

MD1713

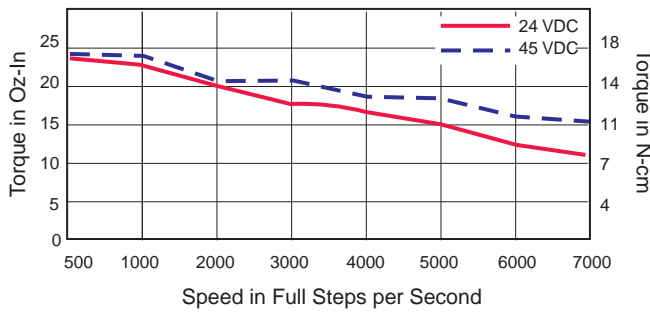

MD1715

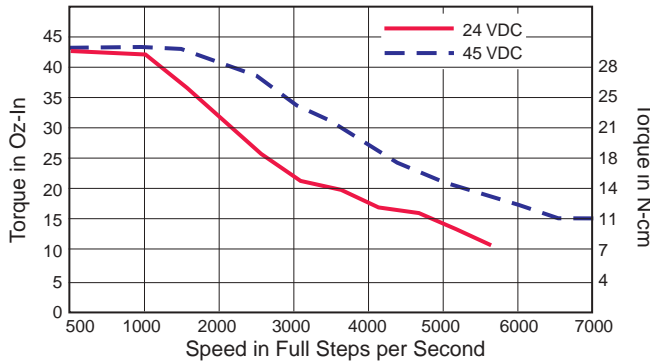

MD1719

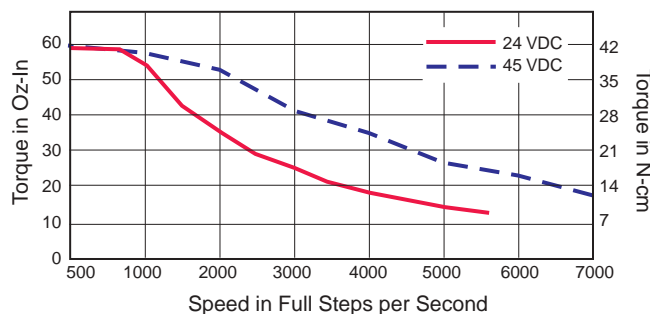

FORCE-SPEED CURVES

Linear Actuator

24 VDC

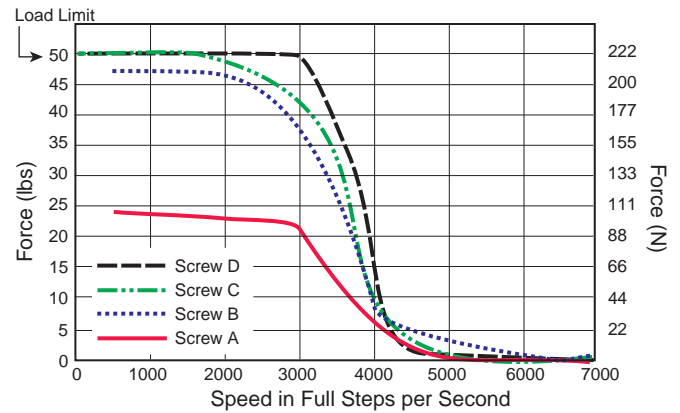

45 VDC

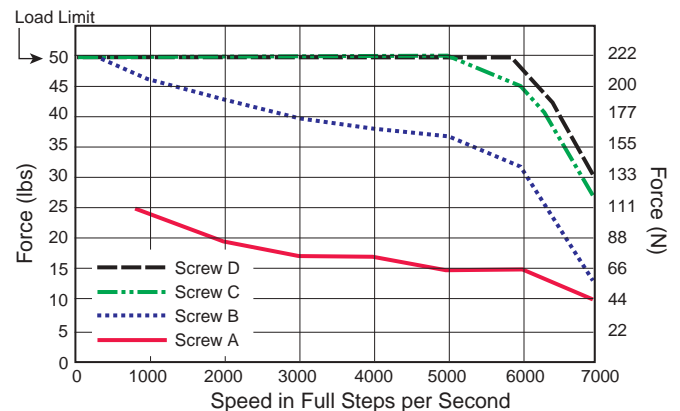

OPTIONS

Stock Items shown in bold italics. Lead times may apply to other options.

PARAMETER SETUP CABLE

A low cost accessory which eliminates the need for the user to wire communications. Included in this cable is built-in logic level shifting circuitry to accommodate the 3.3v ports on some PCs. This cable plugs in easily to connect a standard DB-25 PC parallel port to the 10 pin header (P2) on the MDrive17.
Order Cable Part No. ***MD-CC100-000***.

CONTROL KNOB VERSION

The MDrive17 is available with a factory-mounted knob for manual shaft positioning.

FACTORY-MOUNTED ENCODER VERSION

The MDrive17 is available with a factory-mounted optical encoder. Available line counts: 100, ***200***, 400, 300, ***500***. Encoders are available in both single-end and differential configurations. All encoders have an index mark.

LINEAR ACTUATOR VERSION

The MDrive17 with long life ACME Screw Linear Actuator is available with the following travel/full step:

Screw A 0.00125"/full step
Screw B ***0.000625"/full step***
Screw C ***0.0003125"/full step***
 Screw D 0.00015625"/full step

External linear and captive versions are also available. Consult factory for further information.

The MDrive17 comes standard with a 6" (152.4mm) screw length plus the mounting end thread. Custom lengths are available from 2.0" to 24.0". Custom length screws do not include a mounting end thread.

ORDERING INFORMATION

MDrive17 Speed Control		OPTIONS	
<p style="text-align: center;">Stack Size 32 oz-in = 13[†] 60 oz-in = 15 75 oz-in = 19</p> <p style="text-align: center;">MDO □ 17 □ — OPTION</p> <p>Interface Options F = 12" Flying Leads P = Pluggable Clamp Type Terminal Strip</p>		<p>Add ONE of the options below to the MDrive Speed Control part number</p> <p>Stock items shown in bold italics. Lead times may apply to other options.</p>	
<p>N</p> <p>MDrive With Control Knob</p>		<p>Example #2: MDOP-1719N Adds a Control Knob to the part shown in example #1.</p>	
<p>E</p> <p>Factory Mounted Encoder</p> <p>S = Single End D = Differential</p> <p>Line Counts 100, <i>200</i>, 300, 400, <i>500</i></p>		<p>Example #3: MDOP-1719ED500 Adds a 500 line differential encoder to the part shown in example #1.</p>	
<p>L</p> <p>MDrive17 Linear Actuator[†]</p> <p>Screw Type (Travel/Full Step) A = 0.00125" <i>B = 0.000625"</i> <i>C = 0.0003125"</i> D = 0.00015625"</p> <p>Custom Screw Length Range 2.0" to 24.0" Format XX.X eg. 08.5 for an 8.5" Screw (6.0" Screw Length Standard)</p>		<p>Example #4: MDOP-1713LC105 Speed Control MDrive17 Linear Actuator with a 0.0003125"/Full Step ACME Screw custom cut to 10.5".</p> <p>Note: Linear Actuator Available ONLY in Stack Size 13</p>	

[†]Linear Actuator **ONLY** Available in Stack Size 13. (MDOX-1713LX)

MECHANICAL SPECIFICATIONS

Dimensions in Inches (mm)

Rotary MDrive17: Single Shaft, Encoder & Control Knob

Interface Options

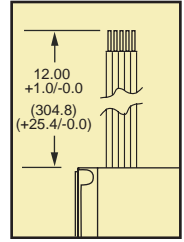
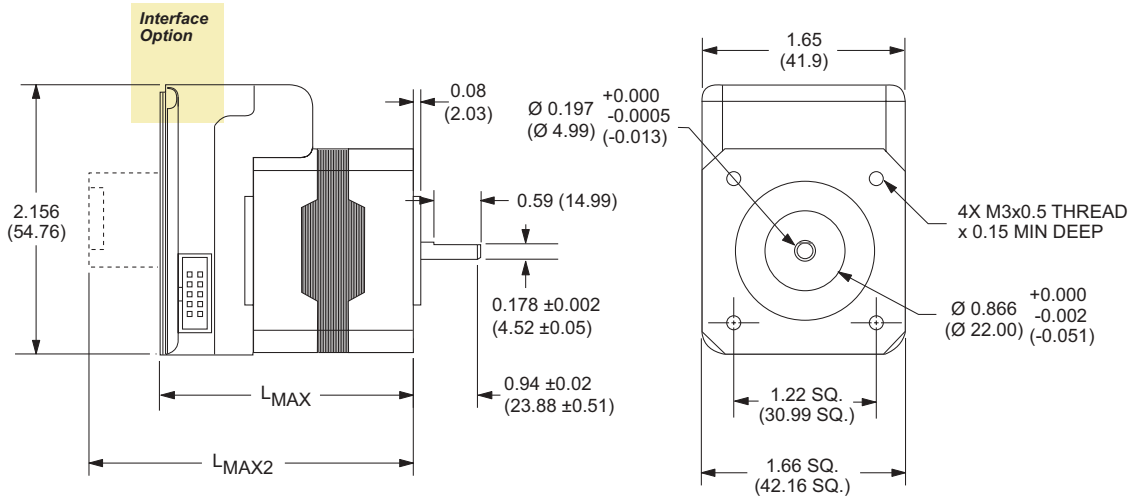

Flying Leads

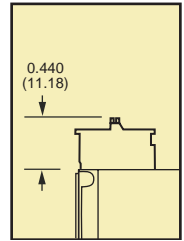

Pluggable Clamp Type Terminal Strip

Lengths in Inches (mm)

Size	L _{MAX} TABLE		L _{MAX2} TABLE	
	ROTARY VERSION	SINGLE-END ENCODER or CONTROL KNOB	DIFFERENTIAL ENCODER	
1713	2.187 (55.56)	2.744 (69.71)	2.957 (75.11)	
1715	2.407 (61.15)	2.965 (75.30)	3.177 (80.70)	
1719	2.786 (70.77)	3.343 (84.92)	3.492 (88.69)	

Linear Actuator MDrive17

