

M DRIVE 23TM

MOTOR+DRIVER



FEATURES

- Integrated Microstepping Drive/ NEMA 23 High Torque Motor
- +12 to +48 or +24 to +75 VDC Input Voltage
- Low Cost
- Extremely Compact
- Optically Isolated Logic Inputs will Accept +5 to +24 VDC Signals, Sourcing or Sinking[†]
- Automatic Current Reduction
- Configurable:
 - Motor Run/Hold Current
 - Motor Direction vs. Direction Input
 - Microstep Resolution to 256 Microsteps/Full Step
- Available Configurations:
 - Single Shaft*
 - Linear Actuator
 - Factory-Mounted Optical Encoder*
 - Double Shaft End with Knob for Manual Positioning*
- Available in Three Motor Lengths*
- Current and Resolution May Be Switched On-The-Fly
- Single Supply
- Interface Types:
 - Keyed and Locking Pin and Receptacle (C Connector)
 - Pluggable Terminal Strip
 - 12" (30.5 cm) Flying Leads
- Graphical User Interface (GUI) for Quick and Easy Parameter Setup

* Rotary Motor Only.

[†] C Connector Version Only. Other Versions Require 5 Volt Sinking Outputs.

DESCRIPTION

The MDrive NEMA 23 high torque Integrated Motor and Driver is ideal for designers who want the simplicity of a motor with on-board electron-

ics, but without the expense of an indexer on each axis. The low cost MDrive23 allows the system designer to decide the best method of control. The MDrive23's integrated electronics eliminates the need to run the motor cabling through the machine, reducing the potential for problems due to electrical noise.

The MDrive23 uses a NEMA 23 frame size 1.8° high torque motor combined with a microstepping drive, and accepts up to 14 resolution settings from 1/2 to 256 microsteps per full step. Setup parameters include Microstep Resolution, Motor Run/Hold Current, and Motor Direction with respect to the direction input. These settings may be changed on-the-fly or downloaded and stored in non-volatile memory with the use of a simple GUI which is provided. This eliminates the need for external switches or resistors. Parameters are changed via an SPI port. Operating voltage for the MDrive23 range from +12 to +48 or +24 to +75 VDC.

The versatile, compact MDrive23 is available in multiple configurations to fit various system needs. These options include: a single shaft stand-alone device, dual shaft rotary motor with optical encoder or control knob, or a long life ACME screw linear actuator. The rotary MDrive23 is also available in three different motor lengths: 18, 22 & 31. Interface connections are accomplished using either a 12 position keyed and locking pin and receptacle, a 7 position terminal strip, or 12" (30.5 cm) flying leads.

The MDrive23 is a compact, powerful and inexpensive solution that will reduce system cost, design and assembly time for a large range of stepping motor applications.

CONFIGURATION UTILITY

The IMS Motor Interface software is an easy to install and use graphical user interface (GUI) for configuring the MDrive23 from the parallel port on your computer. Access the GUI via the IMS SPI Interface included on the CD shipped with the product, or download at www.imshome.com. An optional parameter setup cable is available for ease of connecting and configuring this MDrive product.

Configuration Utility features include:

- Easy installation.
- Automatic detection of MDrive version and communication configuration.
- Will not set out-of-range values.
- Tool-tips display valid range setting for each option.
- Ease of use via single screen interface (*shown below*).



The IMS Motor Interface GUI simplifies MDrive configuring with a single screen interface.

MDRIVE23 MICROSTEPPING SPECIFICATIONS

ELECTRICAL SPECIFICATIONS

Input Voltage (+V) Range* +12 to +48/+24 to +75 VDC
 Isolated Inputs Step Clock, Direction & Enable
 Isolated Input Voltage Range† +5 to +24 VDC
 Step Frequency (Max) 2 MHz
 Steps per Revolution 400, 800, 1000, 1600, 2000,
 3200, 5000, 6400, 10000, 12800,
 25000, 25600, 50000, 51200
 Protection Thermal

† Sourcing or Sinking – C Connector Version Only.

* Graph (right) illustrates power supply current requirements (MAX) per MDrive23. Actual power supply current will depend on load and duty cycle.

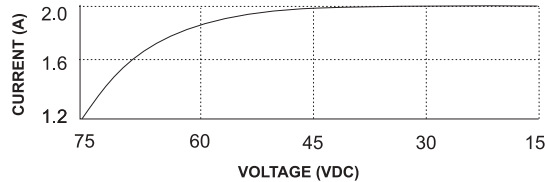

PARAMETERS

SETUP PARAMETERS				
NAME	FUNCTION	RANGE	UNITS	DEFAULT
MHC	Hold Current	0 to 100	percent	5
MRC	Run Current	1 to 100	percent	25
MSEL	Microstep Resolution	2, 4, 5, 8, 10, 16, 25, 32, 50, 64, 125, 128, 250, 256	μsteps per step	256
DIR	Motor Direction	0/1		CW

All parameters are set using the included Configuration Utility and may be changed on-the-fly. An optional parameter setup cable is recommended with the first order.

ENCODER PIN ASSIGNMENTS

ENCODER - Single End		ENCODER - Differential			
1	GROUND	1	GROUND	6	CHANNEL A+
2	INDEX	2	+5 VDC INPUT	7	CHANNEL B-
3	CHANNEL A	3	DIRECTION (OUT)	8	CHANNEL B+
4	+5 VDC INPUT	4	STANDBY -	9	INDEX -
5	CHANNEL B	5	CHANNEL A-	10	INDEX +

Recommended Encoder Mating Connectors Listed Below:

Single End Encoder (ES)

Dupont/Berg 78211-005⁽¹⁾, 65039-032 (use either housing with Ultra-High Spring Force Mini PV terminals [48257-000], 22-36 AWG)
 Molex/Waldom 50-57-9005 (2695 series) (use 16-02-1125 [2759 series] high pressure terminals, 22-30 AWG)
 AMP 103975-4⁽³⁾

Differential Encoder (ED)

3M 89110-0101^(1,2), 89110-0001⁽²⁾
 AMP 101798-3⁽³⁾, 87456-6, 101787-1⁽¹⁾, 11918-1, 7462281^(1,2), 746290-1⁽²⁾
 Amphenol 842-812-1022-118⁽²⁾, 842-812-1033-118^(1,2)
 Dupont/Berg 65043-032, 71602-010^(1,2)
 Robinson Nugent IDS-C10NPK-TR⁽²⁾, IDS-C10PK-TR^(1,2)
 Thomas & Betts 622-1000⁽²⁾, 622-1030^(1,2)
 Molex/Waldom 22-55-2101

⁽¹⁾ Polarized; ⁽²⁾ IDC Ribbon Cable; ⁽³⁾ IDC (Ultra-High or High Spring Force terminals are recommended)

PIN ASSIGNMENTS

Terminal Strip and Flying Leads

CONNECTOR P1		
Pin #	Flying Lead	Function
1	White	+5 VDC OPTOCOUPLER SUPPLY
2	--	NOT CONNECTED
3	Orange	STEP CLOCK INPUT
4	Blue	CW/CCW DIRECTION INPUT
5	Brown	ENABLE INPUT
6	Black	POWER GROUND
7	Red	+V (+12 TO +48 VDC/ +24 TO +75VDC)

10 PIN PIN-HEADER -- P2 (SPI)	
4	CHIP SELECT
5	GROUND
6	+5 VDC OUTPUT
7	MASTER OUT -- SLAVE IN
8	CLOCK
10	MASTER IN -- SLAVE OUT

C Connector

CONNECTOR P1	
Pin #	Function
1	POWER GROUND
2	+V (+12 TO +48 VDC)
3	OPTOCOUPLER REFERENCE
4	STEP CLOCK INPUT
5	ENABLE INPUT
6	CW / CCW DIRECTION INPUT
7	+5 VDC OUTPUT
8	SPI CLOCK
9	COMMUNICATIONS GROUND
10	SPI MASTER IN - SLAVE OUT
11	SPI CHIP SELECT
12	SPI MASTER OUT - SLAVE IN

Mating C Connector Information

Connector Type: AMP Micro Mate-N-Lok
 Receptacle Housing: Part Nos. 1-794617-2
 Receptacle Contacts: See Table Below

Wire Size	Plating	Part Nos.		Tooling Part Nos.	
		Strip	Loose Piece	Applicator	Hand Tool
20-24 AWG	Tin	794606-1	794610-1	680893.*	91501-1
	15μ" 30μ"	794606-2	794610-2		
	30μ"	794606-3	794610-3		
26-30 AWG	Tin	794607-1	794611-1	680894.*	91502-1
	15μ" 30μ"	794607-2	794611-2		
	30μ"	794607-3	794611-3		

* 1=CLS, 2=K-Terminator, 3=G-Terminator
 Extraction Tool 843996-3

For More Information: www.tycoelectronics.com

MOTOR SPECIFICATIONS

MD2218

Holding Torque oz-in (N-cm) 90 (64)
 Detent Torque oz-in (N-cm) 3.9 (2.7)
 Rotor Inertia oz-in-sec² (kg-cm²) 0.0025 (0.18)
 Weight (Motor+Driver) oz (gm) 20.1 (569.8)

MD2222

Holding Torque oz-in (N-cm) 144 (102)
 Detent Torque oz-in (N-cm) 5.6 (3.92)
 Rotor Inertia oz-in-sec² (kg-cm²) 0.0037 (0.26)
 Weight (Motor+Driver) oz (gm) 24.4 (691.7)

MD2231

Holding Torque oz-in (N-cm) 239 (169)
 Detent Torque oz-in (N-cm) 9.7 (6.86)
 Rotor Inertia oz-in-sec² (kg-cm²) 0.0065 (0.46)
 Weight (Motor+Driver) oz (gm) 38.5 (1091.5)

Linear

Weight (without screw) oz (gm) 20.4 (578.3)
 Maximum Thrust lbs (kg) 200 (90.7)
 Maximum Screw Deflection ± 1°
 Backlash inches (mm) 0.005 (0.127)

TORQUE-SPEED CURVES

Rotary Motor

MD2218

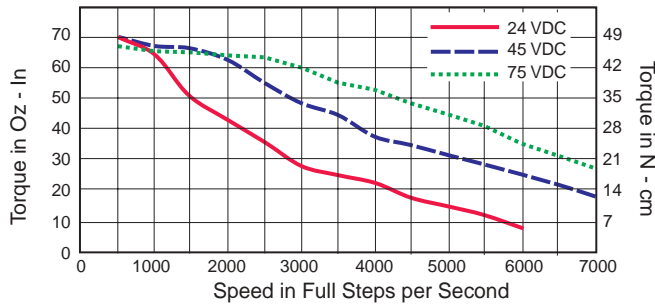

MD2222

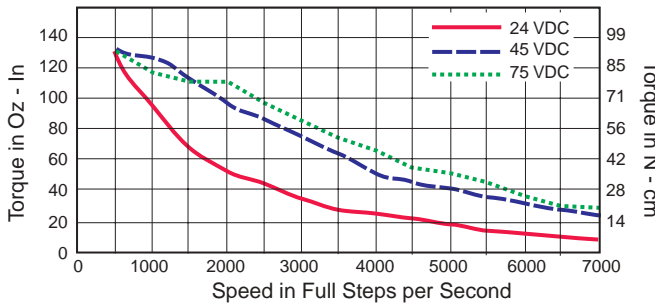

MD2231

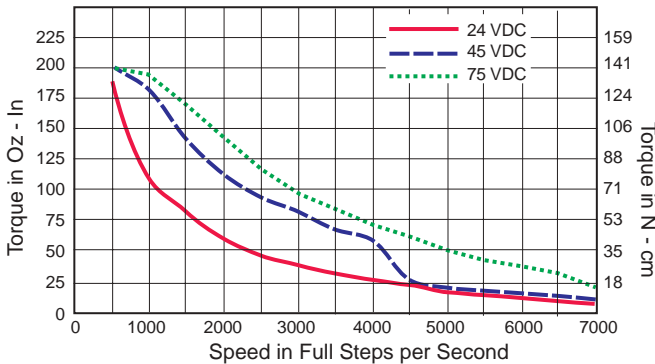

FORCE-SPEED CURVES

Linear Actuator

24 VDC

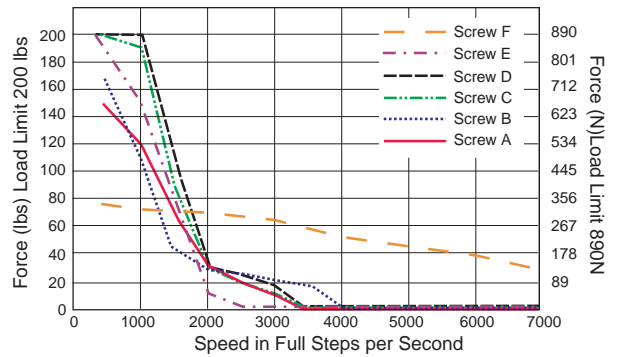

45 VDC

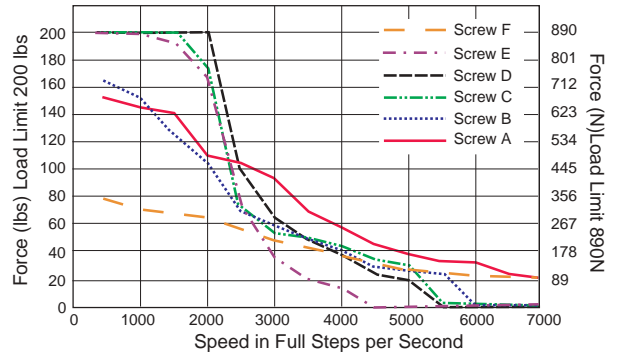

75 VDC

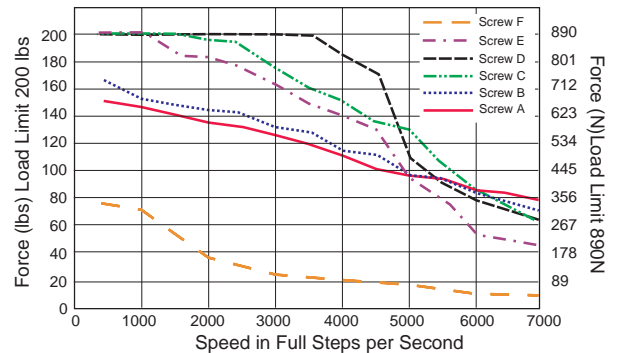

OPTIONS

Stock Items shown in bold italics. Lead times may apply to other options.

PARAMETER SETUP CABLE

A low cost accessory which eliminates the need for the user to wire communications. Included in this cable is built-in logic level shifting circuitry to accommodate the 3.3v ports on some PCs.

This cable plugs in easily to connect a standard DB-25 PC parallel port to the 10 pin header (P2) on the MDrive23. Order Cable Part No. ***MD-CC100-000***. In addition, a cable adaptor is required for the 12 position pin and receptacle connector (P1) on C Connector Versions. Order Adaptor Part No. ***MD-ADP-1723C***.

PROTOTYPE DEVELOPMENT CABLE

To expedite interface to MDrive23 with C Connector. Order Cable Part No. ***ADP-3512-FL***.

FACTORY-MOUNTED ENCODER VERSION

The MDrive23 is available with a factory-mounted optical encoder. Available line counts are 100, ***200***, 300, 400, ***500***. Encoders are available in both single-end and differential configurations. All encoders have an index mark.

CONTROL KNOB VERSION

The MDrive23 is available with a factory-mounted knob for manual shaft positioning.

LINEAR ACTUATOR VERSION

The MDrive23 with long life ACME Screw Linear Actuator is available with the following travel/full step:

Screw F	0.002"/full step
Screw A	0.001"/full step
<i>Screw B</i>	<i>0.0008333"/full step</i>
Screw C	0.0005"/full step
Screw D	0.0004167"/full step
<i>Screw E</i>	<i>0.0003125"/full step</i>

External linear and captive versions are also available. Consult factory for further information.

The MDrive23 comes standard with a 6" (152.4mm) screw length plus the mounting end thread. Custom lengths are available from 2.0" to 24.0". Custom length screws do not include a mounting end thread.

ORDERING INFORMATION

MDrive23 Microstepping

Stack Size

90 oz-in = 18[†]

144 oz-in = 22

239 oz-in = 31

MDM □

Interface Options

F = 12" Flying Leads

C = Pin & Receptacle

P = Pluggable Clamp Type Terminal Strip

□

22 □

Input Voltage

4 = 48 VDC

7 = 75 VDC*

***75 VDC MDrive23 not available with C Connector Version**

— □

OPTION

Example #1: Part Number **MDMP-2222-4** is a Microstepping MDrive23 with pluggable interface, stack size 22, and +12 to +48 VDC input voltage range.

OPTIONS

Add **ONE** of the options below to the MDrive Microstepping part number

Stock items shown in bold italics. Lead times may apply to other options.

<p style="text-align: center;">MDrive With Control Knob</p> <p style="text-align: center; font-size: 24px;">N</p>	<p>Example #2: MDMP-2222-4N Adds a Control Knob to the part shown in example #1.</p>
<p style="text-align: center;">Factory Mounted Encoder</p> <p style="text-align: center; font-size: 24px;">E □ □ □ □</p> <p style="display: flex; justify-content: space-around; font-size: 10px;"> S = Single End D = Differential Line Counts 100, <i>200</i>, 300, 400, <i>500</i> </p>	<p>Example #3: MDMP-2222-4ED500 Adds a 500 line differential encoder to the part shown in example #1.</p>
<p style="text-align: center;">MDrive23 Linear Actuator[†]</p> <p style="text-align: center; font-size: 24px;">L □ □ □ □ □</p> <p style="font-size: 8px;">Screw Type (Travel/Full Step) F = 0.002" A = 0.001" <i>B = 0.0008333"</i> C = 0.0005" D = 0.0004167" <i>E = 0.0003125"</i></p> <p style="font-size: 8px;">Custom Screw Length Range 2.0" to 24.0" Format XX.X eg. 08.5 for an 8.5" Screw (6.0" Screw Length Standard)</p>	<p>Example #4: MDMP-2218-4LC105 Microstepping +48 VDC Input MDrive23 Linear Actuator with a 0.0005"/Full Step ACME Screw custom cut to 10.5".</p> <p>Note: Linear Actuator Available ONLY in Stack Size 18</p>

[†]Linear Actuator **ONLY** Available in Stack Size 18. (MDMX-2218-XLX)

MECHANICAL SPECIFICATIONS

Dimensions in Inches (mm)

Rotary MDrive23: Single Shaft, Encoder & Control Knob

Interface Options

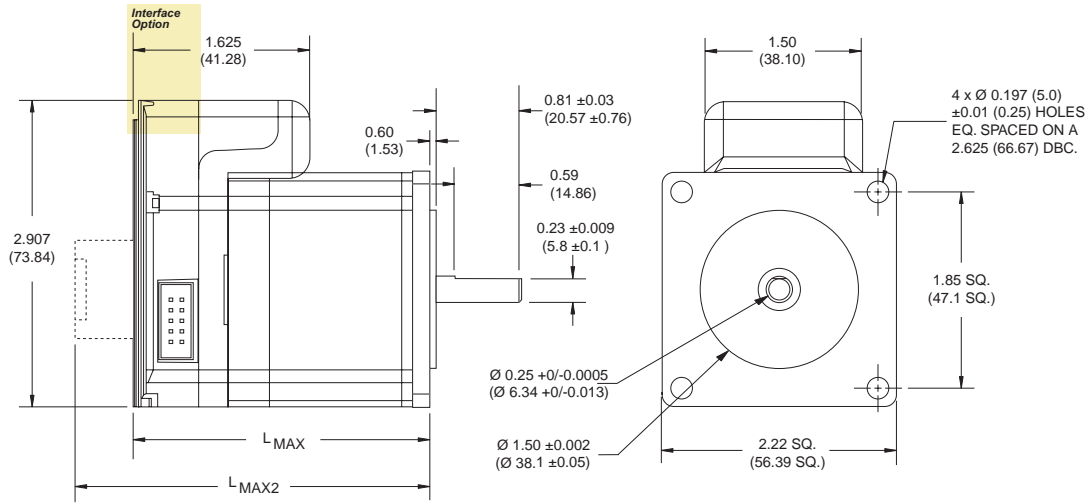

Lengths in Inches (mm)

Size	L _{MAX} TABLE		L _{MAX2} TABLE	
	ROTARY VERSION	SINGLE-END ENCODER or CONTROL KNOB	DIFFERENTIAL ENCODER	
2218	2.632 (66.85)	3.088 (78.44)	3.282 (83.36)	
2222	3.000 (76.20)	3.537 (89.94)	3.741 (95.02)	
2231	3.96 (100.58)	4.416 (112.17)	4.416 (112.17)	

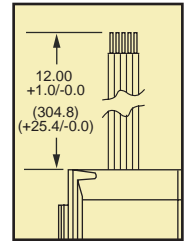

Flying Leads

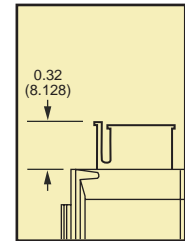

C Connector

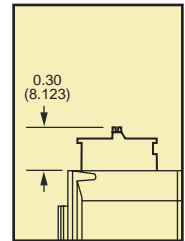

Pluggable Clamp Type Terminal Strip

Linear Actuator MDrive23

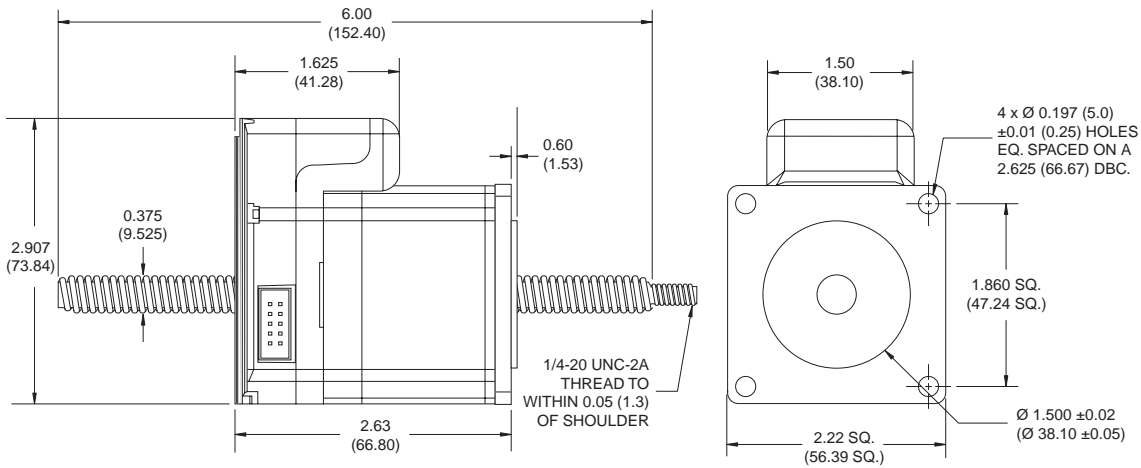

Rev. 11.13.2002