

# IM483I & IM483IE

**HIGH PERFORMANCE MICROSTEPPING DRIVERS**

## QUICK REFERENCE





### IM483I & IM483IE Quick Reference/ Installation Guide

The primary function of this guide is to acquaint the user with the specifications, basic wiring and configuration of the IM483I and the IM483IE Microstepping Drivers. The full product manual is available in Acrobat PDF format on the IMS Product CD. It also may be downloaded from the IMS web site at [www.imshome.com](http://www.imshome.com).

### Notes And Warnings

Please observe the following when handling, connecting and using your IM483I and IM483IE Drivers. Failure to observe these points may result in damage to the drive. All warranty and disclaimer information is located in the full product manual and should be referenced for more information.

 **WARNING!** The IM483I and IM483IE components are sensitive to Electrostatic Discharge (ESD). All handling should be done at an ESD protected workstation.

 **WARNING!** Hazardous voltage levels may be present if using an open frame power supply to power the IM483I and IM483IE.

 **WARNING!** Ensure that the power supply output voltage does not exceed the maximum input voltage of the IM483I and IM483IE.

 **WARNING!** Do not connect or disconnect motor or power leads with the power applied!

 **NOTE!** Additional cooling may be required to limit the plate temperature to 70°C! Optional heat sink and thermal pad are available.

### Thermal Specifications

	Range
Operating Temperature .....	0° to +50°C
Storage Temperature .....	-40° to +125°C
Maximum Plate Temperature* .....	+70°C

\* Additional cooling may be required to limit plate temperature to +70°C.

### Mechanical Specifications

Dimensions in Inches (mm)

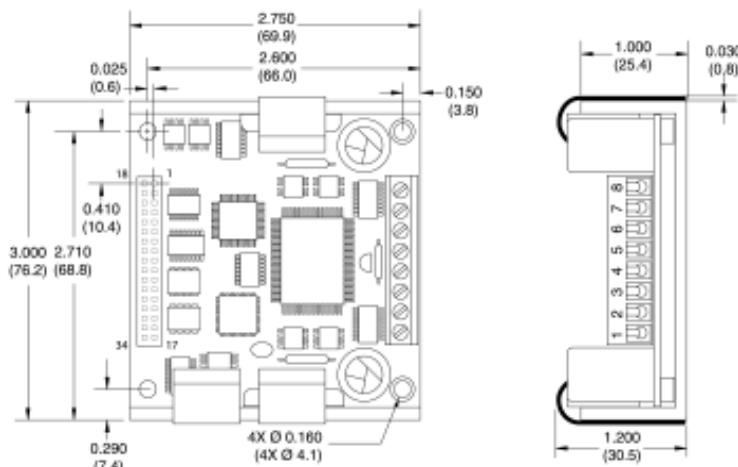

**For More Information:**  
See the complete IM483I / IM483IE Product Manual

### Electrical Specifications

Input Voltage .....	+12 to 48 Volts*
Drive Current (Per Phase)	
Software Selectable .....	0.4 to 3 Amps RMS, 4 Amps Peak
Isolated Logic Inputs .....	Limit A, Limit B, Home, Party
Baud Rate .....	9600
Motor Speed (1.8°/Step) .....	0 to 6,000 RPM
Motor Resolutions	
(1.8°/Step) .....	Auto-Variable, 200, 400, 800, 1600, 3200, 6400, 12800, 25600, 51200
Position Counter .....	± 8,388,607.99
Nonvolatile Memory .....	2k Bytes
Inputs (General Purpose) .....	3 (0 to +5VDC)
Inputs (Dedicated Inputs)	
(Go, Jog +, Jog -, Jog Speed, Soft Stop) .....	5 (0 to + 15VDC)
Outputs (General Purpose) .....	3 (0 to +5VDC)
Encoder Resolution .....	50 – 2000 (In 50 line increments)
Protection .....	Thermal and All Way Short Circuit

\*Includes Motor Back EMF, Power Supply Ripple and High Line.  
Recommended Power Supply: ISP200

### Inputs And Outputs

#### Optically Isolated Inputs

Limit A, Limit B, Home and Party. See the "Pin Descriptions, Connector P1" table for a description.

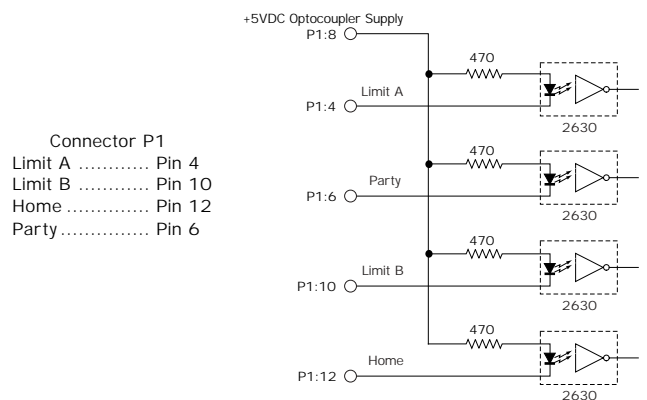

**WARNING!** If using a voltage other than +5VDC, the current through the Optocoupler must not exceed the maximum limit.

The Isolated Inputs may be powered by a DC voltage other than +5VDC. In doing so, care must be taken to limit this current. An external resistor must be placed in series with Pins (4, 10, 12, 6). The value of the resistor is to be calculated such that the input current is equal to the specified value of 7.0 to 15 mA.

#### General Purpose Inputs and Outputs

The IM483I and IM483IE Drivers have three General Purpose Inputs and three General Purpose Outputs.

The Inputs are TTL compatible and are pulled up through a 10KΩ resistor to +5V on the Input.

The Outputs are TTL compatible open collector type and are also pulled to +5V through a 10KΩ resistor.

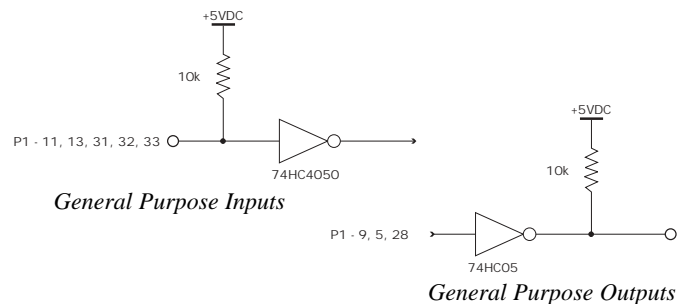

#### Dedicated Inputs

The IM483I and IM483IE Drivers have five dedicated inputs. They are: Go; Soft Stop; Jog +; Jog -; and Jog Speed. The Inputs are pulled up to +5V through a 10KΩ resistor.

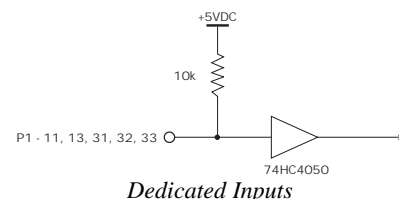

#### Moving Output

The Moving Output is used to indicate when the motor is in motion. When LOW, the indexer is stepping the motor in either direction. When HIGH, the motor is at rest.

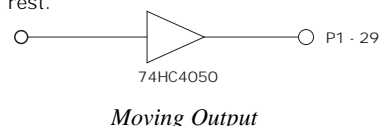

## Encoder Interface

An encoder with TTL level outputs is required to interface with the IM483IE Driver. On board 10KΩ pullups are provided so that encoders with open collector outputs can be used.

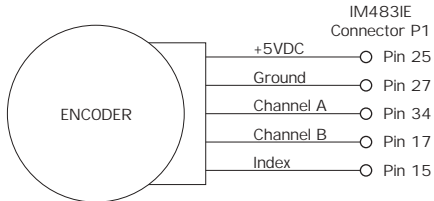

IM483IE Single Ended Encoder Interface

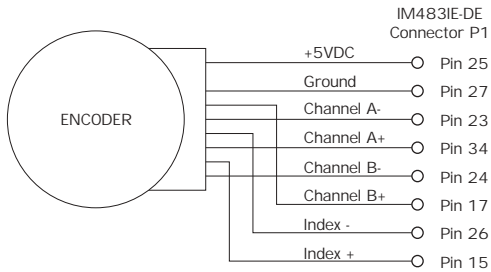

IM483IE Differential Encoder Interface

## Connecting The Motor

### 6 Lead Motors

#### Full Coil Configuration

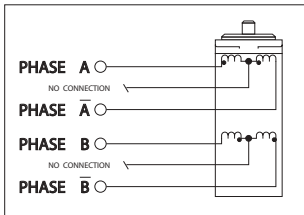

$$\text{Motor Peak Current} = \text{Rated Amps/Phase}$$

#### Half Coil Configuration

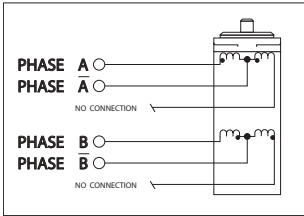

$$\text{Motor Peak Current} = \text{Rated Amps/Phase} \times 1.4$$

### 4 Lead Motors

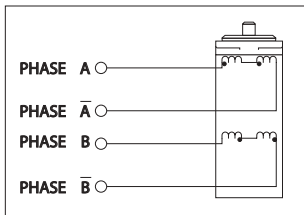

$$\text{Motor Peak Current} = \text{Rated Amps/Phase} \times 1.4$$

### 8 Lead Motors

#### Series Connection

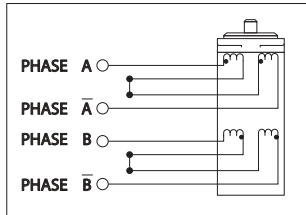

$$\text{Motor Peak Current} = \text{Rated Amps/Phase}$$

$$\text{or} \\ \text{Motor Peak Current} = \text{Bipolar Current Rating} \times 1.4$$

#### Parallel Connection

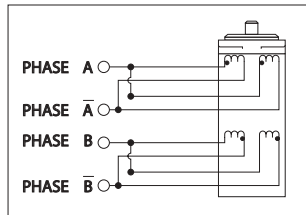

$$\text{Motor Peak Current} = \text{Rated Amps/Phase} \times 2$$

$$\text{or} \\ \text{Motor Peak Current} = \text{Bipolar Current Rating} \times 1.4$$

$$\text{MAXIMUM} \\ \text{Motor Inductance (mH/Phase)} = 0.2 \times \text{Minimum Supply Voltage}$$

## Sample Program

### Program Functionality

- Home to Home Input on Power up.
- Move 2 revolutions forward.
- Turn Output 1 on.
- Wait for Input to return Home.
- Turn Output 1 off.

### Home on Power up, Check IO's

- P 1600 ..... Start Program on Power up  
 D 3 ..... Resolution = 1600 steps/rev  
 V 6400 ..... Max Speed = 4 revs/sec  
 Y 10 60 ..... Hold Current = 10%, Run Current = 60%  
 K 10 10 ..... Accel and Decel Ramp Functions  
 H 1 ..... Variable Resolution (Smooth Operation)  
 F 1000 0 ..... Find Home at 1000 step/sec in + dir.  
 W 0 ..... Wait until motion is complete  
 0 ..... Set origin (Zero Position)  
 G 0 ..... Start running program at address 0  
 P ..... End Program Mode

### 8 Inch Back and Forth

- P 0 ..... Program at address 0  
 + 12800 ..... Move 2 revs in the + direction  
 W 0 ..... Wait for move to complete  
 A 8 ..... Turn Output 1 on (High)  
 G 600 ..... Go to address 600  
 P ..... End Program Mode

### Subroutine

- P 600 ..... Program at address 600  
 L 600 5 ..... Loop to address 600 until Input 3 is low  
 A 0 ..... Turn Output 1 off (low)  
 R 0 ..... Return to the home (zero) position  
 W 0 ..... Wait until motion is complete  
 P ..... End Program Mode

## Pin Descriptions

### Connector P1

Pin #	Pin Name	Function
1	TX —	RS422 Transmit —, (data out from indexer).
2	RX —	RS422 Receive —, (data into indexer).
3	MSEL3	Resolution Selection 3 input. Internally pulled down via a 1.5KΩ resistor.
4	Limit A	Optically isolated, active low limit switch input for "+" direction.
5	Output 2	User controlled output #2. This is an open collector output with an internal 10K Ω pullup resistor to +5VDC
6	Party	Optically isolated party mode select pin: 0 = Party, 1 (Floating) = Single.
7	Input 3	User controlled input #3. Internally pulled up to +5VDC through a 10K Ω resistor.
8	Opto Supply	DC bias for input opto couplers. Internal current limiting resistors for +5VDC are supplied. User must connect resistors in series with optically isolated input signals for voltages greater than +5VDC.
9	Output 1	User controlled output #1. This is an open collector output with an internal 10K Ω pullup resistor.
10	Limit B	Optically isolated, active low limit switch input for "-" direction.
11	Jog +	Active low Jog input for "+" direction. Internally pulled up to +5VDC through a 10K Ω resistor.
12	Home	Optically isolated, active low Home switch input.
13	Jog Speed	Jog Speed input. Low = hi speed, High (floating) = low speed. Internally pulled up to +5VDC through a 10K Ω resistor.
14	Fault	High voltage open collector output indicating driver fault condition. This output will be active when the driver detects an internal fault such as overcurrent or phase short. This output must be pulled high externally. A reset or power down is required to clear the fault condition.
15	Index/Index +	Encoder index marker input. Internally pulled up to +5VDC through a 10K Ω resistor/Differential Encoder Index Mark + input (with Differential Encoder Option installed).
16	Full Step	Open drain output, active for one clock pulse at each on-pole fullstep position.
17	Channel B/ Channel B +	Encoder channel B input. Internally pulled up to + 5VDC through a 10K Ω resistor/Differential Encoder Channel B + input (with Differential Encoder Option installed).
18	TX +	RS422 Transmit + (data out from indexer).
19	RX +	RS422 Receive + (data into indexer).
20	Input 1	User controlled input #1. Internally pulled up to +5VDC through a 10K Ω resistor.
21	SCLK Out/ Receive	Step Clock Output from Indexer/RS232 data into Indexer (with RS232 option installed).
22	DIR Out/ Transmit	Direction Output from Indexer/RS232 data out from indexer (with RS232 option installed).
23	NC/ Channel A -	No Connection/Differential Encoder Channel A - input (with Differential Encoder Option installed).
24	MSEL2/ Channel B -	Resolution select 2 input pin/Differential Encoder Channel B - input (with Differential Encoder Option installed).
25	+5VDC	Logic supply output for Encoder power.
26	Fullstep/ Index -	Fullstep output (see pin 16)/Differential Encoder Index - input (with Differential Encoder Option installed).
27	Ground	Logic Supply Ground connection.
28	Output 3	User controlled output #3. This is an open collector output with an internal 10K Ω pullup resistor to +5VDC.
29	Moving	Moving output, low when indexing is in progress. High when not moving.
30	Input 2	User controlled input #2. Internally pulled up to +5VDC through a 10K Ω resistor.
31	Soft Stop	Active low input to stop indexing using deceleration ramp. Internally pulled up to +5VDC through a 10K Ω resistor.
32	GO	Active low level input to execute a program stored in NVM. Program execution begins at location 0 in memory. Internally pulled up to +5VDC through a 10K Ω resistor. Once executing, the GO input is ignored until the program completes or an Abort/Stop is executed.
33	Jog -	Active low Jog input for "-" direction. Internally pulled up to +5VDC through a 10K Ω resistor.
34	Channel A/ Channel A +	Encoder Channel A input. Internally pulled up to +5VDC through a 10K Ω resistor/Differential Encoder Channel A + input (with Differential Encoder Option installed).

### Connector P2

Pin #	Pin Name	Function
1	NC	No Connection
2	NC	No Connection
3	Ground	Supply Ground
4	V +	Supply Voltage
5	Phase B	Phase B Motor Connection
6	Phase B	Phase B Motor Connection
7	Phase A	Phase A Motor Connection
8	Phase A	Phase A Motor Connection

## IM483I/IE Options And Accessories

- H-4X ..... Heat Sink  
 TN-48 ..... Thermal Pad  
 -8P2 ..... 8 Position 0.045" sq. Pin P2 Connector  
 BB-34-(4P) ..... 34 Pin Breakout Board  
 CV-3222 ..... Inline RS232 to RS422 Converter  
 QuickSTART 1 ..... Graphic User Interface  
 OPT4-232 ..... Plug-on RS232 to RS422 Converter  
 OPT4-DE ..... Differential Encoder Inputs  
 (IM483IE and IM483IE2 Only)  
 -PLG ..... Plug Type Terminal for P2 Connector