

ANALOG BRUSHLESS PWM SERVO AMPLIFIERS SMA8215 STAND ALONE AMPLIFIER MODEL NUMBERING

ANALOG BRUSHLESS PWM SERVO AMPLIFIERS SMA8215 AMPLIFIER MODEL NUMBERING

This section explains the model numbering system for Glentek's SMA8215 Analog Brushless PWM servo amplifier. The model numbering system is designed so that you, our customer, will be able to quickly and accurately create the model number for the amplifier that best suits your needs. In order to accurately select a complete part number, please choose the industry standard mounting configuration which meets your needs (i.e. Module, Stand-Alone or Multi Axis) and then complete the amplifier configuration code per your requirements.

Note: A complete model number example follows each section and includes a full description of the individual codes which make up the complete model number.

Multi Axis Model Numbering

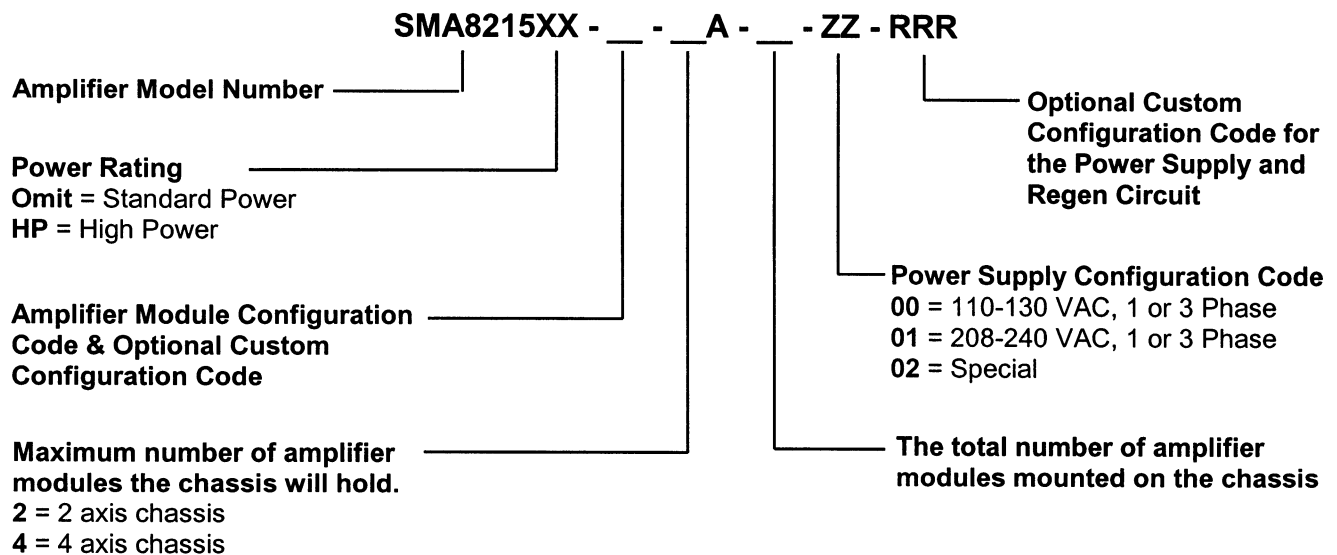

Example: SMA8215HP - 1B00D2E - 2A - 2 - 01

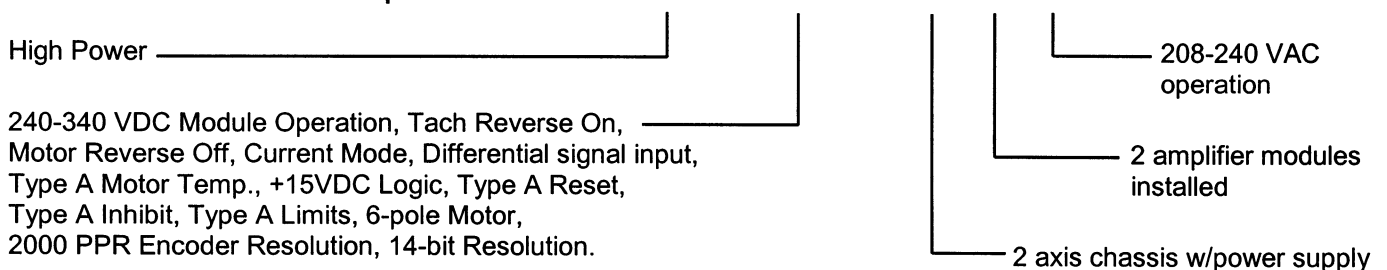

ANALOG BRUSHLESS PWM SERVO AMPLIFIERS SMA8215 STAND ALONE AMPLIFIER MODEL NUMBERING

LOGIC INPUT CONFIGURATION DESCRIPTION:

There are four logic inputs: Limit+, Limit-, Inhibit and Reset In. They may be configured for active-high or active-low signals and pull-up or pull-down termination (type A, B, C and D). All logic inputs have selectable 0 to +5VDC or 0 to +15VDC range. Following is a description of the various types (A, B, C and D) and how they apply to the inhibit input:

Type "A": Requires grounding of input to disable the amplifier (pull-up, active-low).

Type "B": Requires a positive voltage at input to disable the amplifier (pull-down, active-high).

Type "C": Requires grounding of input to enable the amplifier (pull-up, active-high).

Type "D": Requires a positive voltage at input to enable the amplifier (pull-down, active-low).

Amplifier Configuration Code

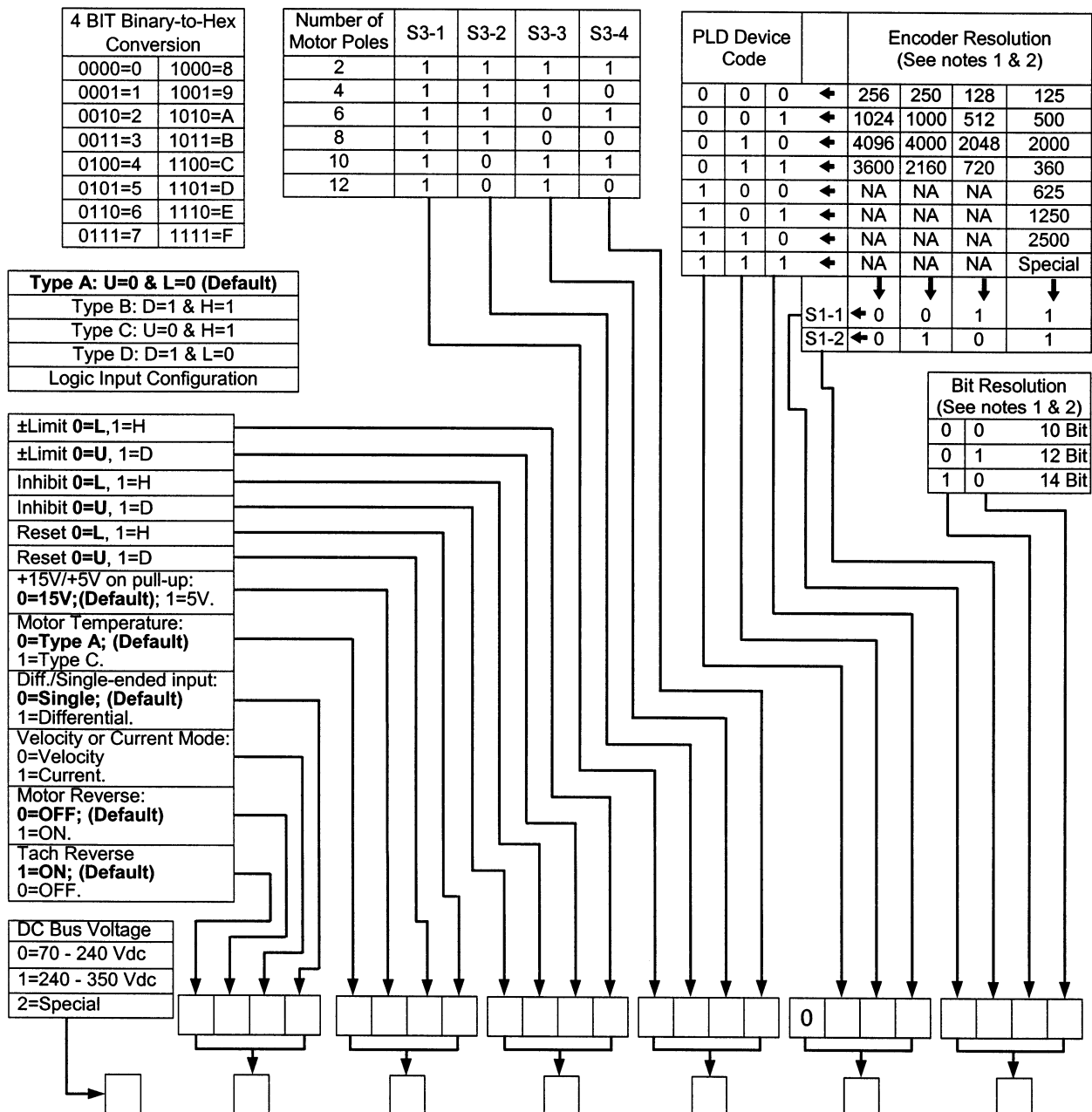

Note 1: With 12 Bit resolution, maximum speed is limited to 15,000 RPM and maximum encoder resolution is limited to 1024 PPR.

Note 2: With 14 Bit resolution, maximum speed is limited to 3,500 RPM and maximum encoder resolution is limited to 4096 PPR.