

PANTHER LD

HIGH PERFORMANCE MICROSTEPPING SYSTEM

QUICK REFERENCE



Panther LD Quick Reference

The primary function of Panther LD Quick Reference Guide is to acquaint the user with the specifications, basic wiring and configuration of the Panther LD Microstepping Driver. The full product manual is available in Acrobat PDF format on the IMS Product CD, shipped with the product. It also may be downloaded from the IMS web site at <http://www.imshome.com>.

Notes And Warnings

Please observe the following when handling, connecting and using your Panther LD Driver. Failure to observe these points may result in damage to the drive. All warranty and disclaimer information is located in the full product manual on the CD and should be referenced for more information.



WARNING! The Panther LD Driver components are sensitive to Electrostatic Discharge (ESD). All handling should be done at an ESD protected workstation.



WARNING! Hazardous Voltage Levels are present.



WARNING! Do not operate the Panther LD Driver without a Current Adjustment Resistor!

A resistor **MUST** be placed between the Current Adjust Input (Pin 12 on Connector P2) and ground (Pin 11 on Connector P2) to keep the Panther LD Driver and/or motor in a safe operating range.

Operating Characteristics

Step Frequency (Max) 10 Mhz
 Steps/Revolution (1.8° Motor) 400, 800, 1000, 1600, 2000, 3200, 5000, 6400, 10000, 12800, 25000, 25600, 50000, 51200
 Status Indicators Power, Fault
 Chopping Rate 20 kHz
 Protection Thermal and All Way Short Circuit
 Internal Fuse 5mm, 250 volt, 2 Amp Slow Blow

Thermal Specifications

Operating Temperature 0 to +50° C
 Storage Temperature -40° to +125° C
 Case Temperature 0 to +60° C

Electrical Specifications

	MIN	TYP	MAX	UNITS
Input Voltage	90		128	VAC
Phase Output Current (RMS)	0.4		3	A
Phase Output Current (Peak)			4	A
Active Power Dissipation ($I_{OUT}=3A$ RMS)			12	W
Input Forward Current (Isolated Inputs) Step Clock, Direction, Enable, Reset	7.0		15	mA
Input Forward Voltage	1.5		1.7	V
Input Reverse Breakdown Voltage	5			V
Output Current (Fault Output)			25	mA
Collector-Emitter Voltage (Fault Output)			140	V
Collector-Emitter Saturation Voltage Fault Output ($I_{CS} = 25$ mA DC)			0.2	V

All values taken at 25° C, at 120 VAC.
 NOTE: The aluminum housing is electrically isolated.

Connector P1

Pin #	Pin Name	Function
1	Phase A	Phase A Motor Connection
2	Phase /A	Phase /A Motor Connection
3	Phase B	Phase B Motor Connection
4	Phase /B	Phase /B Motor Connection
5	AC Input Neutral	Neutral connection of the AC power
6	AC Input Line	Line (hot) connection of the AC power.



WARNING! Follow the correct polarity of the AC Input to prevent damage.

Connector P2

Pin #	Pin Name	Function
1-4	Microstep Select	Microstep Select Inputs (MSEL): These inputs select the number of microsteps per step. They are non-isolated binary coded inputs. (See the MSEL table)
5	Step Clock	Step Clock Input: A positive going edge advances the motor one increment. The size of the increment depends on the Microstep Select Inputs.
6	Direction	Direction Input: This input is used to change direction of the motor. The physical direction is dependent on the connection of the motor windings.
7	Enable	Enable Input: This input is used to enable/disable the output section of the driver. When HIGH (open) the outputs are enabled. When LOW (closed) the outputs are disabled. However, this input does not inhibit the step clock. When enabled, the outputs will update by the number of clock pulses applied to the driver while it was disabled.
8	Reset	Reset Input: When LOW (closed) this input will reset the driver (outputs will disable). When released HIGH (open) the driver will be at its initial state (Phase A off, Phase B full on).
9	Opto Supply	Optocoupler Supply: A +5 VDC input used to supply current to the Isolated Inputs. A higher voltage may be used but care must be taken to limit the current through the optocoupler.
10	Fault	Fault Output: This open collector output indicates a short has occurred. This output is active LOW.
11	Ground	Ground: A non-isolated internal driver ground.
12	Current Adjust	Phase Current Adjust Input: A resistor is connected between this input and ground (Pin 11) to adjust the maximum phase current to the motor. A resistor MUST BE connected to the input.
13	Reduction Adjust	Current Reduction Adjust Input: A resistor is connected between this input and the Current Adjust Input (Pin 12) to proportionally reduce the current in both motor windings approximately one second after the last positive edge of the Step Clock Input. The amount of reduction will depend on the value of the resistor used.

Motor Connections

6 Lead Motors

Full Coil Configuration

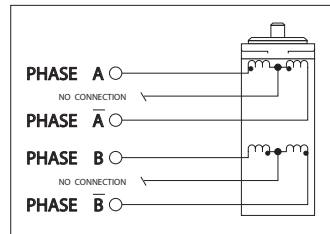

$$\text{Motor Peak Current} = \text{Rated Amps/Phase}$$

8 Lead Motors

Series Connection

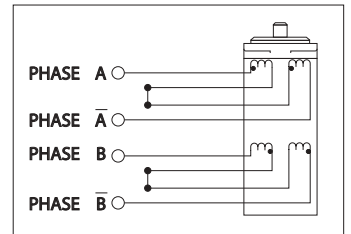

$$\text{Motor Peak Current} = \text{Rated Amps/Phase}$$

or

$$\text{Motor Peak Current} = \text{Bipolar Current Rating} \times 1.4$$

Half Coil Configuration

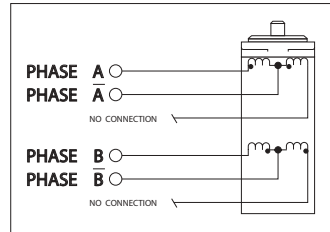

$$\text{Motor Peak Current} = \text{Rated Amps/Phase} \times 1.4$$

Parallel Connection

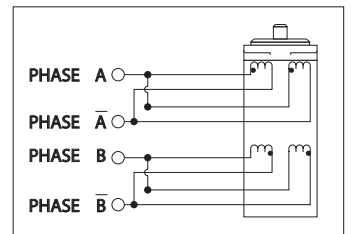

$$\text{Motor Peak Current} = \text{Rated Amps/Phase} \times 2$$

or

$$\text{Motor Peak Current} = \text{Bipolar Current Rating} \times 1.4$$

4 Lead Motors

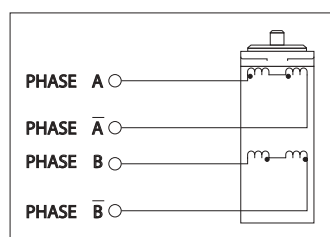

$$\text{Motor Peak Current} = \text{Rated Amps/Phase} \times 1.4$$

MAXIMUM
 Motor Inductance (mH/Phase) =
 0.2 x Minimum Supply Voltage



WARNING! Do not connect or disconnect the motor leads or the AC power leads with the power applied!

Replacing The Internal Fuse

- Remove the front panel.
- Remove the four allen head screws on the side of the unit.
- Carefully slide the printed circuit board out about two inches.
- The fuse is located behind the P1 connector.

NOTE: Under normal operating conditions it should not be necessary to replace the fuse. If the unit operates incorrectly or there is no power indicated, the unit should be returned to the factory for service.

Output Current Adjust

The Output Current on the Panther LD is set by a 1/8 Watt (or higher) 1% resistor which is installed between the Current Adjust Input (Pin 12) and Ground (Pin 11) on Connector P2.

The Output Current must be determined relative to the Phase Current of the motor you are going to use. Please see Page 7 of the Panther LD Manual for details.

Output Current Adjust Resistor Values

Output Current	Resistor Value 1%
0.4	200
0.6	301
0.8	392
1.0	499
1.2	590
1.4	698
1.6	787
1.8	887
2.0	1000
2.2	1100
2.4	1210
2.6	1300
2.8	1400
3.0	1500
3.2	1580
3.4	1690
3.6	1780
3.8	1910
4.0	2000

WARNING! A current adjustment resistor is always necessary to keep the Driver and/or Motor in a safe operating range. **DO NOT** operate the Panther LD Driver without a current adjustment resistor in place.

Automatic Current Reduction

The Panther LD also has the capability of automatically reducing the current in the motor windings at the completion of a move. The reduction occurs approximately 0.5 seconds after the last positive going edge of the Step Clock Input. The Panther LD will then revert back to the original current setting at the next positive edge of the Step Clock Input. A 1/8 Watt (or higher) 1% resistor must be installed between the Current Adjust Input (Pin 12) and the Current Reduction Input (Pin 13) on Connector P2.

To calculate the resistance for the Current Reduction Resistor use the following formula.

Where:

- R(Current Reduction) = Resistor Value
- Output Current Reduced = Desired Reduced Current
- R(Current Adjust) = Resistance of Current Adjust Resistor

$$R^*(\text{Current Reduction}) = \frac{\text{Output Current Reduced} \times R^*(\text{Current Adjust})}{0.002 \times R^*(\text{Current Adjust}) - \text{Output Current Reduced}}$$

* R = Ohms

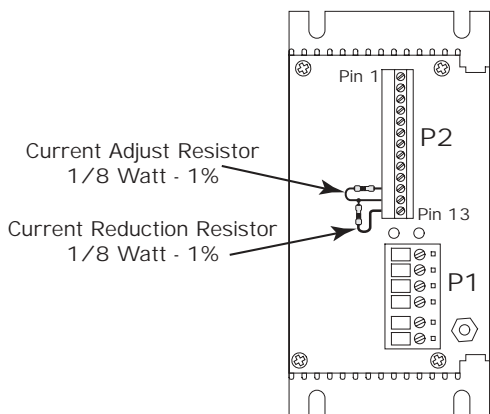

Panther LD Current Adjust and Current Reduction Resistors

NOTE: When connecting the Output Current Adjust Resistor or the Automatic Current Reduction Resistor the leads must be kept as short as possible to help minimize noise coupled into the driver.

Microstep Selection

Resolution		Microstep Select			
Microsteps/Step	Steps/Rev	MSEL0	MSEL1	MSEL2	MSEL3
Binary Microstep Resolution Settings (1.8° Motor)					
2	400	Ground	Ground	Ground	Ground
4	800	Floating*	Ground	Ground	Ground
8	1,600	Ground	Floating	Ground	Ground
16	3,200	Floating	Floating	Ground	Ground
32	6,400	Ground	Ground	Floating	Ground
64	12,800	Floating	Ground	Floating	Ground
128	25,600	Ground	Floating	Floating	Ground
256	51,200	Floating	Floating	Floating	Ground

Decimal Microstep Resolution Settings (1.8° Motor)					
5	1,000	Ground	Ground	Ground	Floating
10	2,000	Floating	Ground	Ground	Floating
25	5,000	Ground	Floating	Ground	Floating
50	10,000	Floating	Floating	Ground	Floating
125	25,000	Ground	Ground	Floating	Floating
250	50,000	Floating	Ground	Floating	Floating

Invalid Resolution Settings: May Cause Erratic Operation					
		Ground	Floating	Floating	Floating
		Floating	Floating	Floating	Floating

* Leaving the Inputs "floating" is equivalent to +5 VDC (logic) being connected to the Input. The Inputs are internally pulled up to +5 VDC with a 10kΩ resistor.

Mechanical Specifications

Dimensions in Inches (mm)

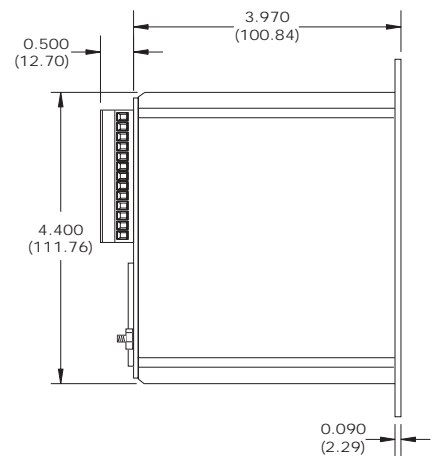
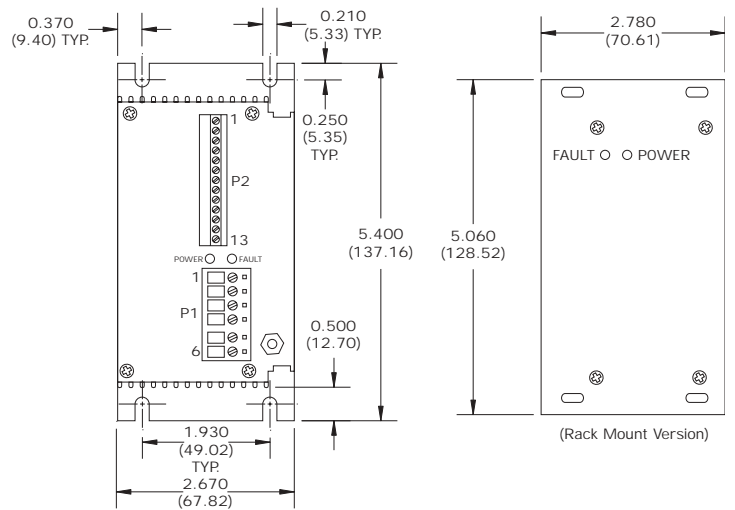

Isolated Inputs

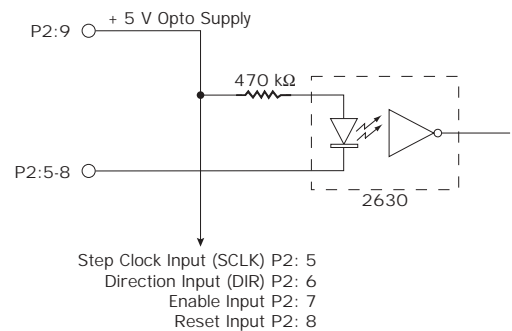

For More Information:
See the complete Panther LD Product Manual