

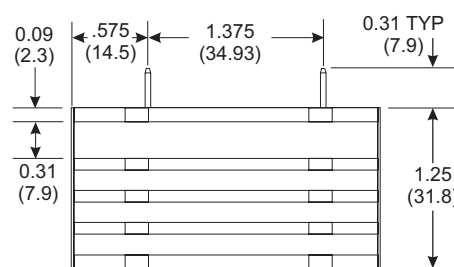

IB462 and IB463

dimensions in inches (mm)

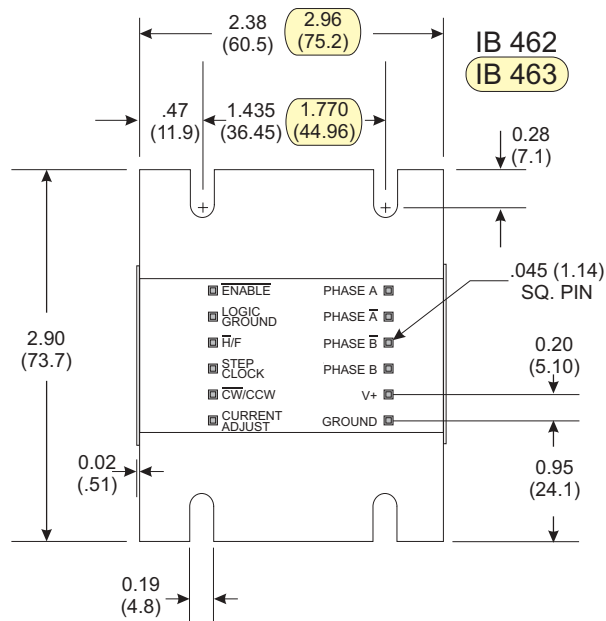

IB104, IB106, and IB1010

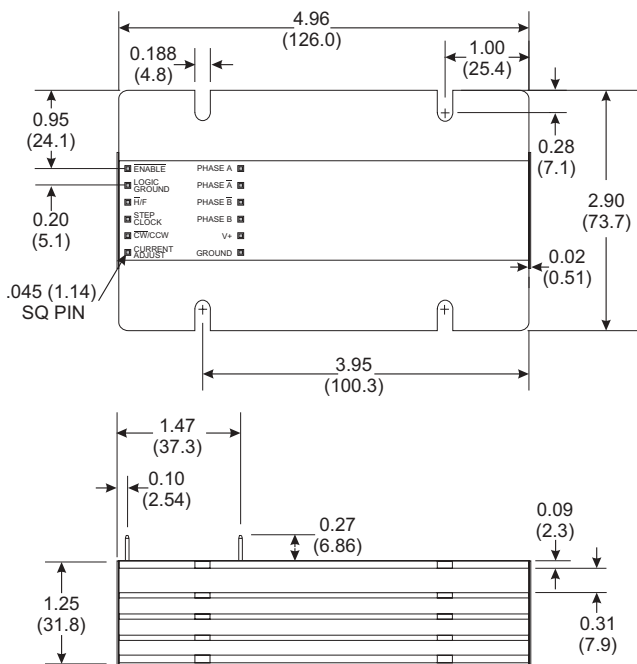

IB SERIES

HALF/FULL STEP STEPPING MOTOR DRIVERS

QUICK REFERENCE



IB Series Drivers Quick Reference/Installation Guide

The primary function of this guide is to acquaint the user with the specifications, basic wiring and configuration of the IB Series Half/Full Step Stepping Motor Drivers. The full product manual is available in Acrobat PDF format on the IMS Product CD. It also may be downloaded from the IMS web site at www.imshome.com.

Notes And Warnings

Please observe the following when handling, connecting and using your IB Series Driver. Failure to observe these points may result in damage to the drive. All warranty and disclaimer information is located in the full product manual and should be referenced for more information.

- WARNING!** The IB series drives have components which are sensitive to Electrostatic Discharge (ESD). All handling should be done at an ESD protected workstation.
- WARNING!** Hazardous voltage levels may be present if using an open frame power supply to power your IB series drive!
- WARNING!** Ensure that the power supply output voltage does not exceed the maximum input voltage of the IB series drive that you are using!
- WARNING!** A current limiting resistor is **required** when interfacing to the isolated inputs or damage will occur to the drive. See the Product Manual, Part 1, Section 5 for interface details.
- WARNING!** Do not use any flux removers that contain trichloroethane or hydrochlorofluorocarbons (HCFCs) as corrosive damage will occur to the internal drive components!

For More Information:
See the complete IB Series Product Manual

Thermal Specifications

Ambient Temperature 0° to +50°C
Storage Temperature -40° to +125°C
Maximum Case Temperature +70°C

Current Adjust Equations

IB462	IB463	IB104	IB106	IB1010
+V +12 to +40VDC Output Current 2A	+V +12 to +40VDC Output Current 3.5A	+V +24 to +80VDC Output Current 4A	+V +24 to +80VDC Output Current 6A	+V +24 to +80VDC Output Current 9A
CURRENT ADJUST EQUATION	CURRENT ADJUST EQUATION	CURRENT ADJUST EQUATION	CURRENT ADJUST EQUATION	CURRENT ADJUST EQUATION
$R_{ADJ} = \frac{400}{(2/I_{RUN}) - 1}$ <small>R_{ADJ} = Adjust Resistor I_{RUN} = Run Current</small>	$R_{ADJ} = \frac{279}{(3.5/I_{RUN}) - 1}$ <small>R_{ADJ} = Adjust Resistor I_{RUN} = Run Current</small>	$R_{ADJ} = \frac{315}{(4/I_{RUN}) - 1}$ <small>R_{ADJ} = Adjust Resistor I_{RUN} = Run Current</small>	$R_{ADJ} = \frac{241}{(6/I_{RUN}) - 1}$ <small>R_{ADJ} = Adjust Resistor I_{RUN} = Run Current</small>	$R_{ADJ} = \frac{355}{(9/I_{RUN}) - 1}$ <small>R_{ADJ} = Adjust Resistor I_{RUN} = Run Current</small>

Electrical Specifications - All IB Drives

Driver	+V Motor Voltage (VDC)	I _i Input Current (A max)	I _Q Quiescent Current (mA)	V _{CE sat(h)} Source (V) (max)	V _{CE sat(l)} Source (V) (max)	R _{DS High} (Ω) (max)	R _{DS Low} (Ω) (max)	B _{VR} Input Reverse Breakdown (V min)	V _F Input Forward Voltage (V max)	I _F Input Forward Current (mA)	T _{CLK} Step Pulse Width (ms)	T _S Setup Time (ms)	T _H Hold Time (ms)	F _C Commutate Frequency (kHz)
IB462	12 - 40	2	75 (typ)	2.6	2.4			5	1.75	5 - 15	3	2	5.5	40
IB463	12 - 40	3.5	90 (typ)	2.4	2.3			5	1.75	5 - 15	3	2	5.5	40
IB104	24 - 80	4	144 (max)			0.20	0.20	5	1.75	5 - 15	3	2	5.5	250
IB106	24 - 80	6	144 (max)			0.117	0.77	5	1.75	5 - 15	3	2	5.5	250
IB1010	24 - 80	9	144 (max)			0.117	0.77	5	1.75	5 - 15	3	2	5.5	250

Pin Assignment and Description

PIN #	FUNCTION	DETAILS
1	Enable	When Logic LOW, the phase outputs are enabled.
2	Logic Ground	Logic Signal Common. This pin is the return path for the logic inputs. In order to maintain isolation this pin should not be connected to pin 7 (Power Ground).
3	Half/Full Step Input	Half/Full Step select input. When in a Logic LOW state the drive will be in half step mode. When HIGH the drive will be operating in full step mode.
4	Step Clock Input	Step Clock input. An active HIGH pulse on this input advances the motor one increment. The step occurs on the falling edge of this signal.
5	CW/CCW Input	Clockwise/counterclockwise direction control input. Physical direction of motor rotation depends on the connection of the motor windings. This input is internally synchronized.
6	Current Adjust	Phase Current Adjustment input. A resistor is connected between this input and Power Ground (Pin 7) to adjust the phase current of the motor.
7	Power Ground	Power supply return (GND).
8	+V	Power supply input.
9	ØB	Motor phase B output.
10	ØB̄	Motor phase B̄ output.
11	ØĀ	Motor phase Ā output.
12	ØA	Motor phase A output.

Motor Specifications

6 Lead Motors

Full Coil Configuration

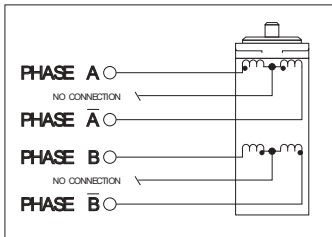

Motor Peak Current =
Rated Amps/Phase

Half Coil Configuration

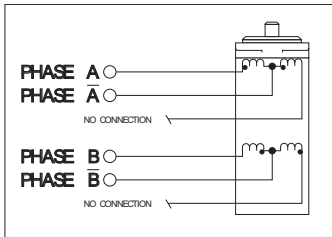

Motor Peak Current =
Rated Amps/Phase x 1.4

4 Lead Motors

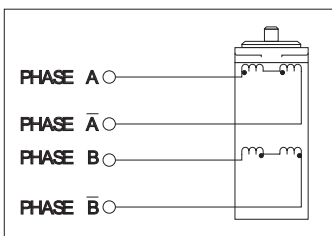

Motor Peak Current =
Rated Amps/Phase x 1.4

8 Lead Motors

Series Connection

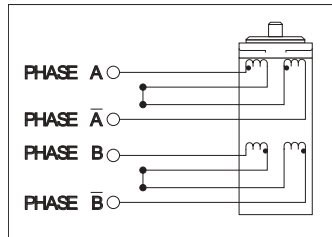

Motor Peak Current =
Rated Amps/Phase
or
Motor Peak Current =
Bipolar Current Rating x 1.4

Parallel Connection

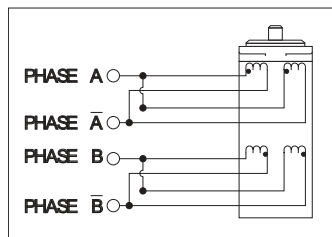

Motor Peak Current =
Rated Amps/Phase x 2
or
Motor Peak Current =
Bipolar Current Rating x 1.4

MAXIMUM
Motor Inductance (mH/Phase) =
0.2 x Minimum Supply Voltage

Basic Connections

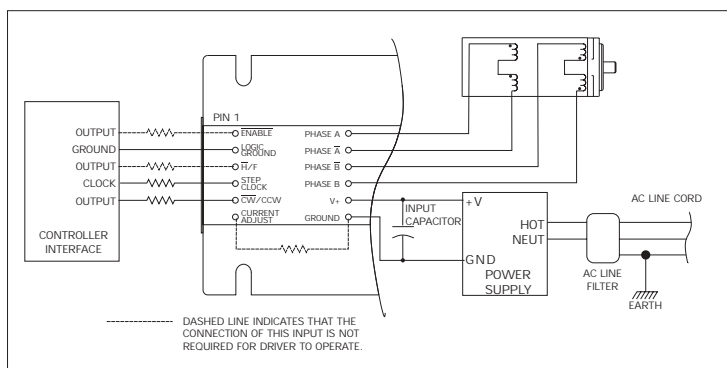

WARNING! A current limiting resistor or recommended interface is required in series with the logic inputs! Use of these inputs without this resistor or recommended interface will result in damage to the drive!

Controlling the Output Current

The IB Series Drivers are configured internally to operate at full current. A resistor must be placed between Pin 6 (Current Adjust) and Pin 7 (Power Ground). The resistor value will be different for each Drive model and desired current. Refer to the charts in Part II (Hardware Reference) of the IB Series Manual.

The Output Current can be set at a fixed value by placing a resistor between Pin 6 and Pin 7. It is also possible to switch the Current Adjust Resistor value from one setting to another. Two circuit examples are shown below.

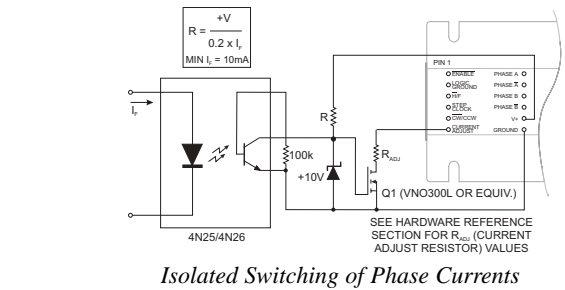
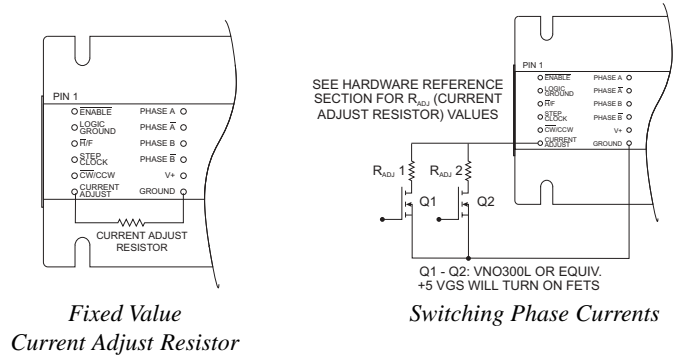

WARNING! If a resistor is not placed between Pins 6 and 7, the drive will be at full current. Ensure it does not exceed the motor specifications.

Logic Interface Example Circuits

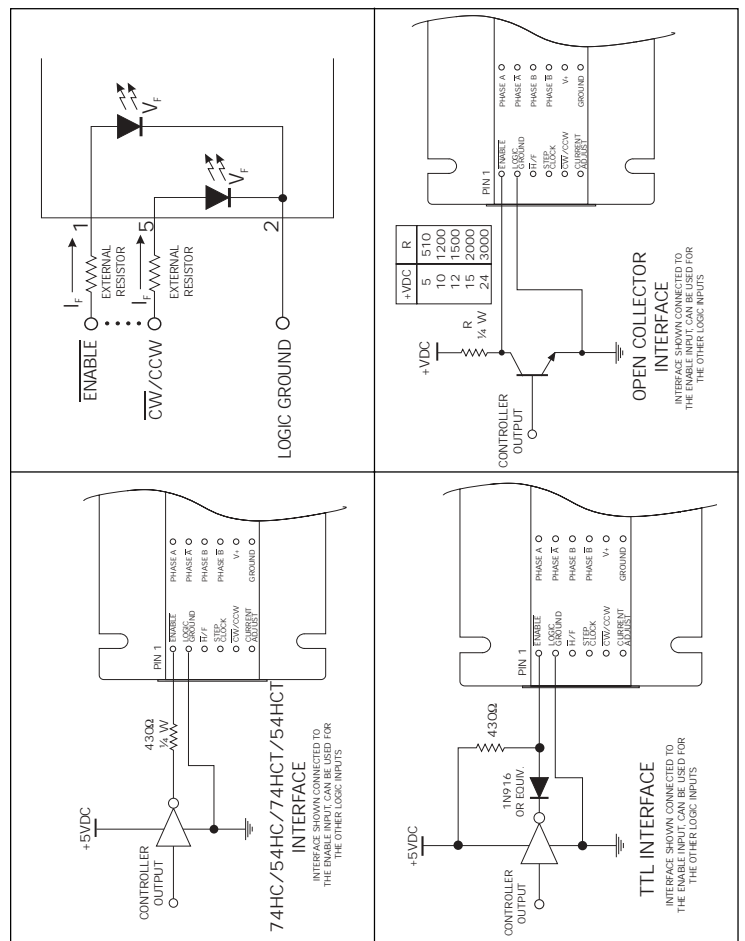

IB Series Options and Accessories

- IB462S Sinking Inputs Version of IB462
- IB463S Sinking Inputs Version of IB463
- OPT140 Interface Board for IB462/463, IB104/106/1010
- TS-6 6 Pin Terminal Strips (Pair)
- H-4X Heat Sink for IB462/463
- TN-462/463 Non-Isolating Thermal Pad for IB462/463
- TI-462/463 Isolating Thermal Pad for IB462/463
- H-100 Heat Sink for IB104/106/1010
- TN-100 Non-Isolating Thermal Pad for IB104/106/1010